



ML WOOD

Spare and Wear Parts list

Screen Refiner Mill
ML-SRM 09-17

without electrical controls

B. Maier & R.Loith GmbH Wood Technology * An der Bleiche 9 * 33813 Oerlinghausen (Germany)

Tel: +49 (0)5202 – 99689 - 0
Fax: +49 (0)5202 – 99689 - 90
Mail: info@ml-wood.com
Web: www.ml-wood.com

Volksbank Paderborn-Höxter-Detmold
BLZ 472 601 21 Konto 3 206 577 300
IBAN-Nr.: DE02 4726 0121 3206 5773 00
SWIFT (BIC) DGPBDE3MXXX

Sparkasse Bielefeld
BLZ 480 501 61 Konto 50 082 999
IBAN-Nr.: DE72 4805 0161 0050 0829 99
SWIFT (BIC) SPBIDE3BXXX

Reg.-Gericht: Lemgo HRB 9088
GF: Dipl.-Ing. Robert Loth
GF: Annika Körtner
Ust-IdNr.: DE 20 63 28 082



ML WOOD

Assembly parts: SRM 09-17

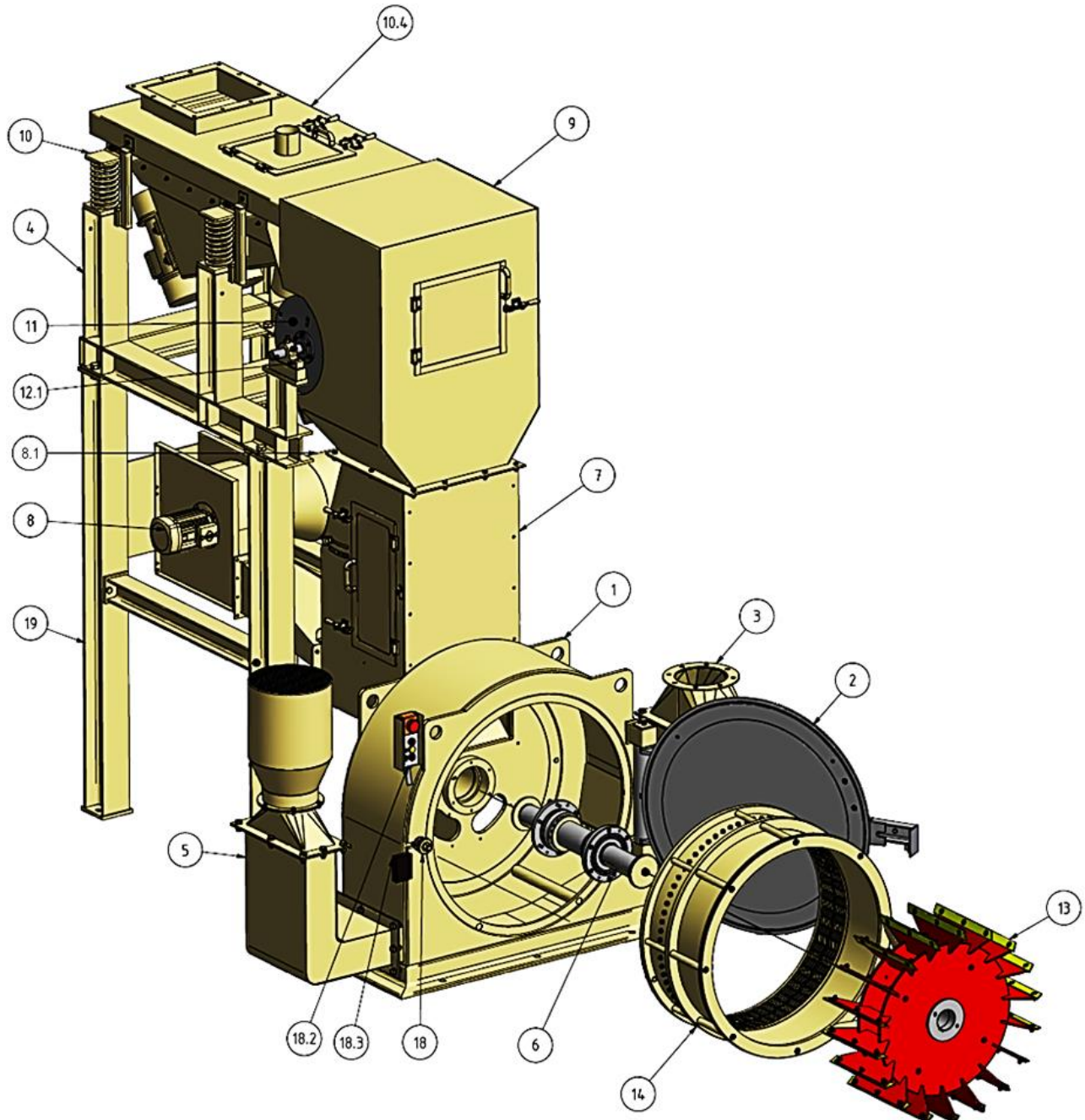

B. Maier & R.Loith GmbH Wood Technology * An der Bleiche 9 * 33813 Oerlinghausen (Germany)

Tel: +49 (0)5202 – 99689 - 0
Fax: +49 (0)5202 – 99689 - 90
Mail: info@ml-wood.com
Web: www.ml-wood.com

Volksbank Paderborn-Höxter-Detmold
BLZ 472 601 21 Konto 3 206 577 300
IBAN-Nr.: DE02 4726 0121 3206 5773 00
SWIFT (BIC) DGPBDE3MXXX

Sparkasse Bielefeld
BLZ 480 501 61 Konto 50 082 999
IBAN-Nr.: DE72 4805 0161 0050 0829 99
SWIFT (BIC) SPBIDE3BXXX

Reg.-Gericht: Lemgo HRB 9088
GF: Dipl.-Ing. Robert Loth
GF: Annika Körtner
Ust-IdNr.: DE 20 63 28 082



ML WOOD

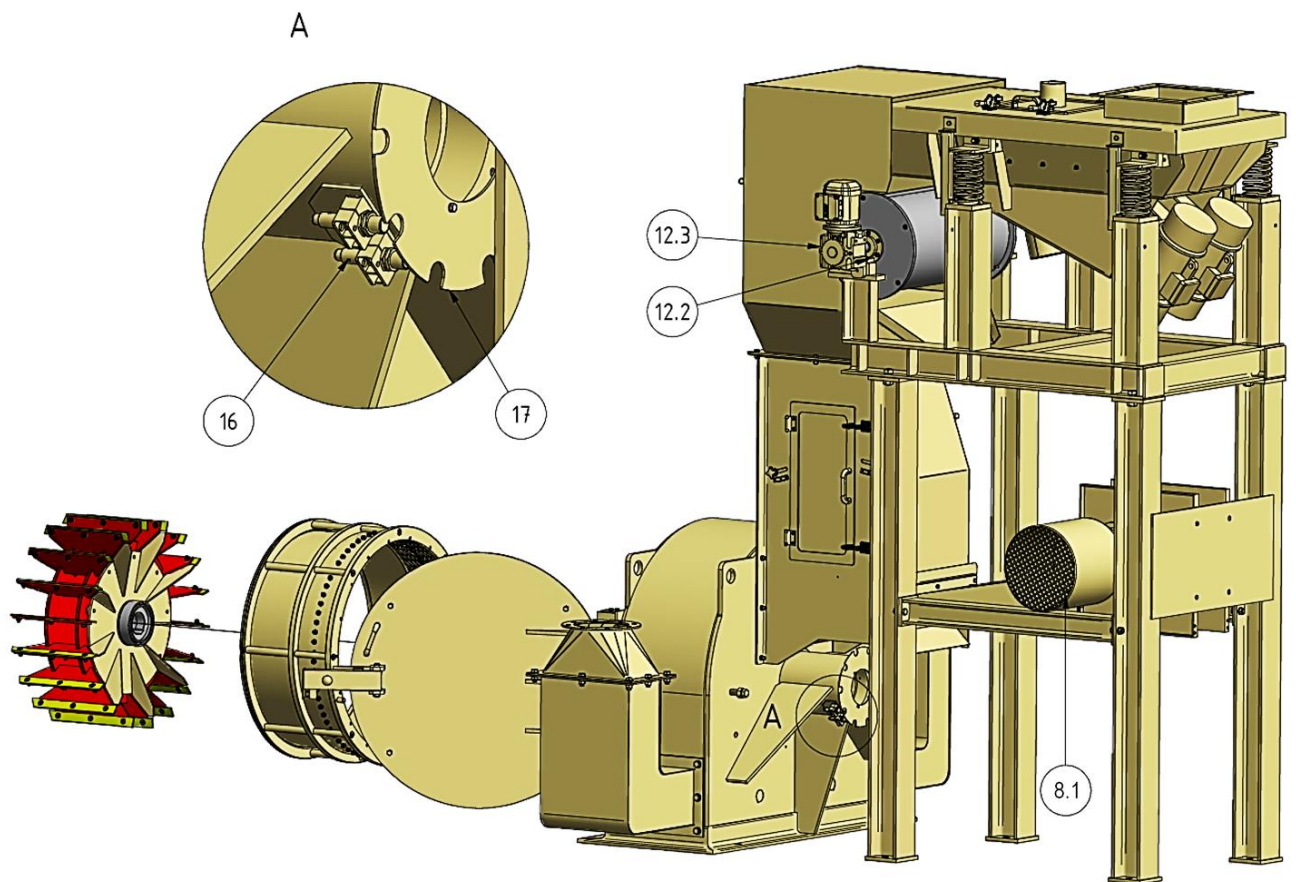

B. Maier & R.Loith GmbH Wood Technology * An der Bleiche 9 * 33813 Oerlinghausen (Germany)

Tel: +49 (0)5202 – 99689 - 0
Fax: +49 (0)5202 – 99689 - 90
Mail: info@ml-wood.com
Web: www.ml-wood.com

Volksbank Paderborn-Höxter-Detmold
BLZ 472 601 21 Konto 3 206 577 300
IBAN-Nr.: DE02 4726 0121 3206 5773 00
SWIFT (BIC) DGPBDE3MXXX

Sparkasse Bielefeld
BLZ 480 501 61 Konto 50 082 999
IBAN-Nr.: DE72 4805 0161 0050 0829 99
SWIFT (BIC) SPBIDE3BXXX

Reg.-Gericht: Lemgo HRB 9088
GF: Dipl.-Ing. Robert Loth
GF: Annika Körtner
Ust-IdNr.: DE 20 63 28 082



ML WOOD

1. Assembly parts

When ordering spare and wear parts please indicate in the machine no. (see type plate on the machine) and the corresponding article-no. of the requested part.

In order to reduce potential down-times to a minimum, we recommend to keep a small stock of wear parts.

Please refer to the following list for spare and wear parts:

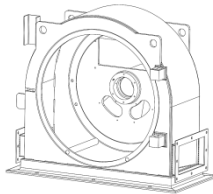
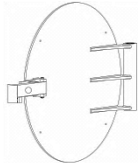
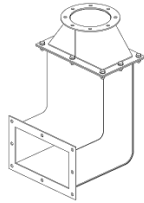
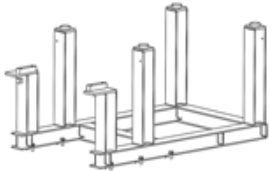
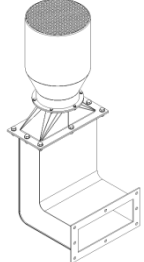
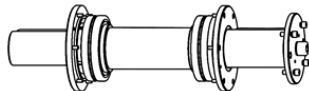
Item.	Description	
1	Casing with flange	
2	Door equipped	
3	Duct connection for material extraction	
4	Steel girder frame for vibration conveyor and magnet drum	
5	Air inlet bypass with butterfly valve	
6	Rotor shaft with bearing	

B. Maier & R.Loeth GmbH Wood Technology * An der Bleiche 9 * 33813 Oerlinghausen (Germany)

Tel: +49 (0)5202 – 99689 - 0
Fax: +49 (0)5202 – 99689 - 90
Mail: info@ml-wood.com
Web: www.ml-wood.com



Volksbank Paderborn-Höxter-Detmold
BLZ 472 601 21 Konto 3 206 577 300
IBAN-Nr.: DE02 4726 0121 3206 5773 00
SWIFT (BIC) DGPBDE3MXXX

Sparkasse Bielefeld
BLZ 480 501 61 Konto 50 082 999
IBAN-Nr.: DE72 4805 0161 0050 0829 99
SWIFT (BIC) SPBIDE3BXXX

Reg.-Gericht: Lemgo HRB 9088
GF: Dipl.-Ing. Robert Loth
GF: Annika Körtner
Ust-IdNr.: DE 20 63 28 082

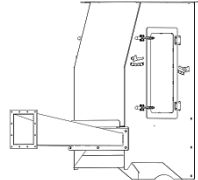
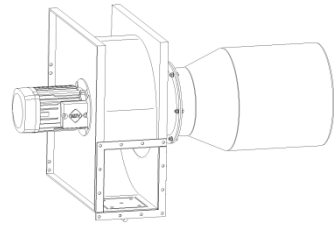
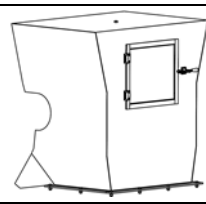
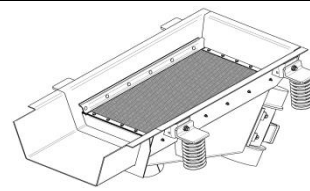
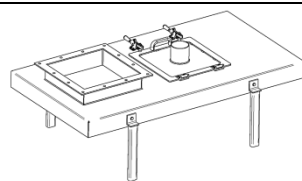
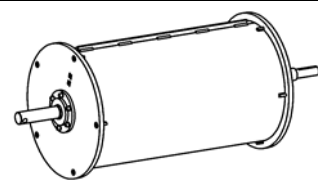

ML WOOD

Item.	Description	
7	Wind sifter	
8	Cross ventilation fan	
9	Dust Hood with control door	
10	Vibration conveyor with Conidur screen	
10.4	Dust cover to Vibration conveyor with Conidur screen	
11	Magnet drum	
12.1	Pedestal bearing block	
12.2	Pedestal bearing	

B. Maier & R.Loith GmbH Wood Technology * An der Bleiche 9 * 33813 Oerlinghausen (Germany)

Tel: +49 (0)5202 – 99689 - 0
Fax: +49 (0)5202 – 99689 - 90
Mail: info@ml-wood.com
Web: www.ml-wood.com





Volksbank Paderborn-Höxter-Detmold
BLZ 472 601 21 Konto 3 206 577 300
IBAN-Nr.: DE02 4726 0121 3206 5773 00
SWIFT (BIC) DGPBDE3MXXX

Sparkasse Bielefeld
BLZ 480 501 61 Konto 50 082 999
IBAN-Nr.: DE72 4805 0161 0050 0829 99
SWIFT (BIC) SPBIDE3BXXX

Reg.-Gericht: Lemgo HRB 9088
GF: Dipl.-Ing. Robert Loth
GF: Annika Körtner
Ust-IdNr.: DE 20 63 28 082

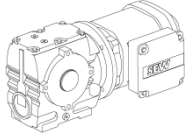
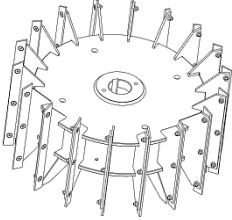
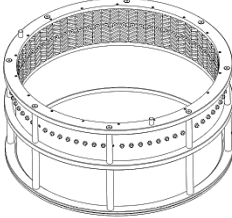
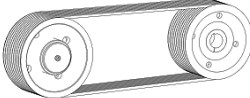

ML WOOD

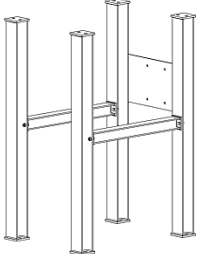
Item.	Description	
12.3	Gear motor für magnet drum	
13	Rotor fully equipped	
14	Grind Ring with screen fully equipped	
15	V-Belt drive (not supplied)	
16	Proximity switch	
17	Sensor disc to detect standstill	
18	Door lock	
19	Support Structure	

B. Maier & R.Loith GmbH Wood Technology * An der Bleiche 9 * 33813 Oerlinghausen (Germany)

Tel: +49 (0)5202 – 99689 - 0
Fax: +49 (0)5202 – 99689 - 90
Mail: info@ml-wood.com
Web: www.ml-wood.com

Volksbank Paderborn-Höxter-Detmold
BLZ 472 601 21 Konto 3 206 577 300
IBAN-Nr.: DE02 4726 0121 3206 5773 00
SWIFT (BIC) DGPBDE3MXXX

Sparkasse Bielefeld
BLZ 480 501 61 Konto 50 082 999
IBAN-Nr.: DE72 4805 0161 0050 0829 99
SWIFT (BIC) SPBIDE3BXXX

Reg.-Gericht: Lemgo HRB 9088
GF: Dipl.-Ing. Robert Loth
GF: Annika Körtner
Ust-IdNr.: DE 20 63 28 082



ML WOOD

2. Spare and wear parts

Attention: (S = Spare Part, W = Wear Part)

When ordering spare and wear parts please indicate the machine no. (See type plate on the machine) and the corresponding article-no. of the requested part.

In order to reduce potential down-times to a minimum, we recommend you to keep a small stock of parts.

Item.	Pcs.	Description	
1	1	Casing	S
3	1	Duct connection for material extraction	S
3.1	8	Hexagon screw	S
3.2	16	Retaining washer	S
3.3	8	Hexagon nut	S
4	1	Steel girder frame for vibration conveyor and magnet drum	S
4.1	8	Hexagon screw	S
4.2	8	Retaining washer, Schnorr	S
4.3	8	Hexagon nut	S
5	1	Air inlet bypass with butterfly valve	S
5.1	8	Hexagon screw	S
5.2	16	Retaining washer	S
5.3	8	Hexagon nut	S
5.4	1	Butterfly valve	S
5.5	6	Hexagon screw	S
5.6	12	Retaining washer	S
5.7	6	Hexagon nut	S
7	1	Wind sifter	S
7.1	6	Hexagon screw	S
7.2	6	Retaining washer, Schnorr	S
7.3	6	Hexagon nut	S
8	1	Cross ventilation fan	S
8.1	1	Butterfly valve	S
8.2	6	Hexagon screw	S
8.3	12	Retaining washer	S

B. Maier & R.Loeth GmbH Wood Technology * An der Bleiche 9 * 33813 Oerlinghausen (Germany)

Tel: +49 (0)5202 – 99689 - 0
Fax: +49 (0)5202 – 99689 - 90
Mail: info@ml-wood.com
Web: www.ml-wood.com

Volksbank Paderborn-Höxter-Detmold
BLZ 472 601 21 Konto 3 206 577 300
IBAN-Nr.: DE02 4726 0121 3206 5773 00
SWIFT (BIC) DGPBDE3MXXX

Sparkasse Bielefeld
BLZ 480 501 61 Konto 50 082 999
IBAN-Nr.: DE72 4805 0161 0050 0829 99
SWIFT (BIC) SPBIDE3BXXX

Reg.-Gericht: Lemgo HRB 9088
GF: Dipl.-Ing. Robert Loth
GF: Annika Körtner
Ust-IdNr.: DE 20 63 28 082



ML WOOD

8.4	6	Hexagon nut	S
9	1	Dust Hood with control door	S
9.1	10	Hexagon screw	S
9.2	10	Retaining washer, Schnorr	S
9.3	10	Hexagon nut	S
9.4	1	Horizontal spanner head	S
10	1	Vibration conveyor with Conidur screen	S
10.1	2	Vibration motors	S
10.2	4	Pressure spring	S
10.3	1	Conidure screen 4 mm	S
10.4	1	Dust cover to Vibration conveyor with Conidur screen	S
10.4.1	2	Horizontal spanner head	S
11	1	Magnet drum	S
11.1	1	Gear motor	S
16+17	1	Standstill control with Proximity switch and Sensor disc	S
18	1	Door lock	S
18.1	1	Big sliding disk to door shutter nut	S
18.2	1	Push-button control unit	S
18.3	1	Electromagnetic safety door locking	S
19	1	Support Structure	S
19.1	8	Hexagon screw	S
19.2	8	Retaining washer, Schnorr	S
19.3	8	Hexagon nut	S

B. Maier & R.Loith GmbH Wood Technology * An der Bleiche 9 * 33813 Oerlinghausen (Germany)

Tel: +49 (0)5202 – 99689 - 0
Fax: +49 (0)5202 – 99689 - 90
Mail: info@ml-wood.com
Web: www.ml-wood.com

Volksbank Paderborn-Höxter-Detmold
BLZ 472 601 21 Konto 3 206 577 300
IBAN-Nr.: DE02 4726 0121 3206 5773 00
SWIFT (BIC) DGPBDE3MXXX

Sparkasse Bielefeld
BLZ 480 501 61 Konto 50 082 999
IBAN-Nr.: DE72 4805 0161 0050 0829 99
SWIFT (BIC) SPBIDE3BXXX

Reg.-Gericht: Lemgo HRB 9088
GF: Dipl.-Ing. Robert Loth
GF: Annika Körtner
Ust-IdNr.: DE 20 63 28 082



ML WOOD

2.1 Item 2: Door equipped

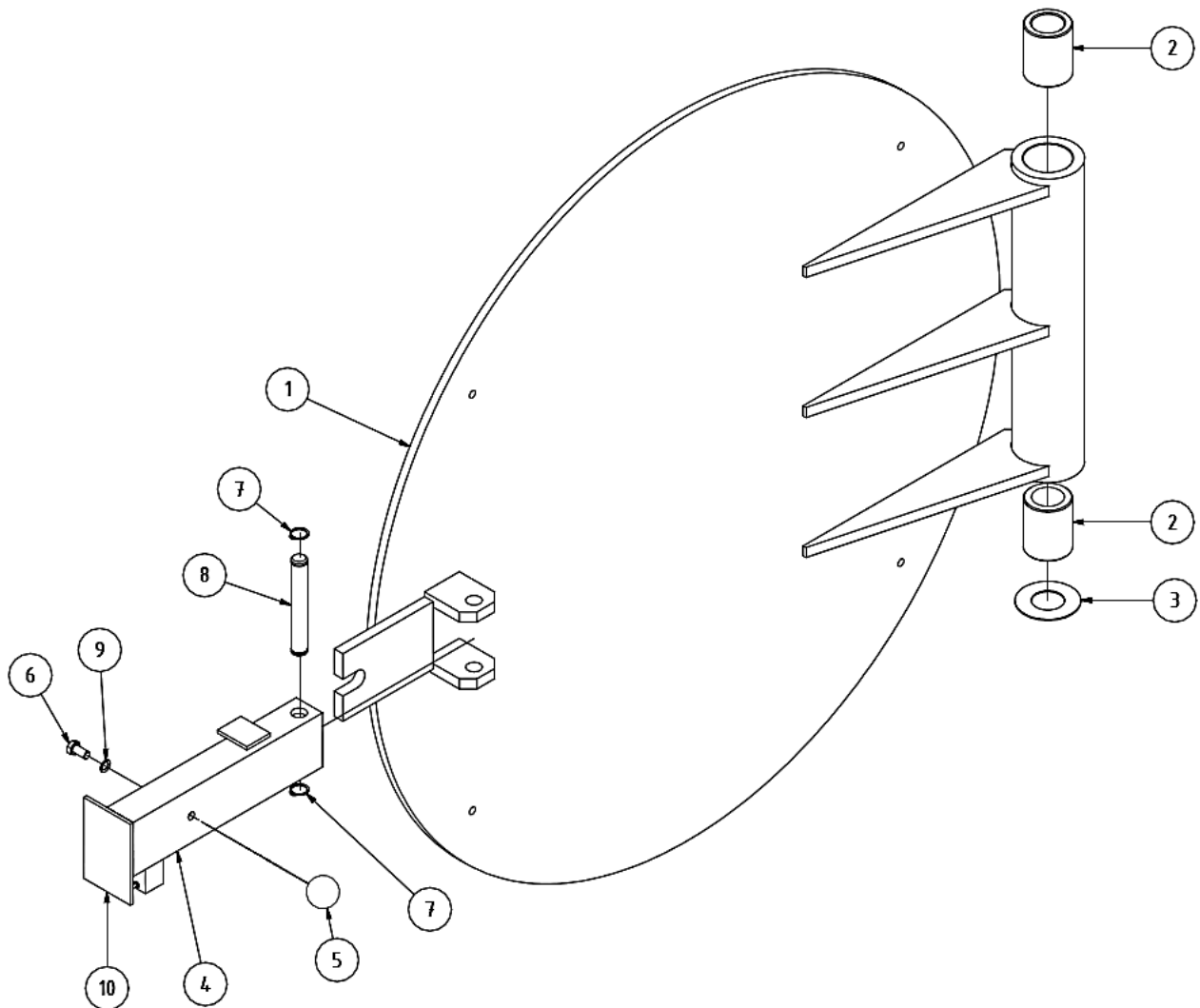

Please refer to the following list for spare and wear parts:

B. Maier & R.Loith GmbH Wood Technology * An der Bleiche 9 * 33813 Oerlinghausen (Germany)

Tel: +49 (0)5202 – 99689 - 0
Fax: +49 (0)5202 – 99689 - 90
Mail: info@ml-wood.com
Web: www.ml-wood.com

Volksbank Paderborn-Höxter-Detmold
BLZ 472 601 21 Konto 3 206 577 300
IBAN-Nr.: DE02 4726 0121 3206 5773 00
SWIFT (BIC) DGPBDE3MXXX

Sparkasse Bielefeld
BLZ 480 501 61 Konto 50 082 999
IBAN-Nr.: DE72 4805 0161 0050 0829 99
SWIFT (BIC) SPBIDE3BXXX

Reg.-Gericht: Lemgo HRB 9088
GF: Dipl.-Ing. Robert Loth
GF: Annika Körtner
Ust-IdNr.: DE 20 63 28 082



ML WOOD

Item.	Pcs.	Description	
1	1	Door	S
2	2	Bush to door hinge	S
3	1	Washer	S
4	1	Door lever arm	S
5	1	Knob for door locking	S
6	1	Hexagon socket screw	S
7	2	Retaining ring for bolt	S
8	1	Bolt for door locking	S
9	1	Retaining washer, Schnorr	S
10	1	Door locking device	S
10.1	1	Coded limit switch	S

B. Maier & R.Loith GmbH Wood Technology * An der Bleiche 9 * 33813 Oerlinghausen (Germany)

Tel: +49 (0)5202 – 99689 - 0
Fax: +49 (0)5202 – 99689 - 90
Mail: info@ml-wood.com
Web: www.ml-wood.com

Volksbank Paderborn-Höxter-Detmold
BLZ 472 601 21 Konto 3 206 577 300
IBAN-Nr.: DE02 4726 0121 3206 5773 00
SWIFT (BIC) DGPBDE3MXXX

Sparkasse Bielefeld
BLZ 480 501 61 Konto 50 082 999
IBAN-Nr.: DE72 4805 0161 0050 0829 99
SWIFT (BIC) SPBIDE3BXXX

Reg.-Gericht: Lemgo HRB 9088
GF: Dipl.-Ing. Robert Loth
GF: Annika Körtner
Ust-IdNr.: DE 20 63 28 082



ML WOOD

2.2 Item 6: Rotor Shaft with Bearings

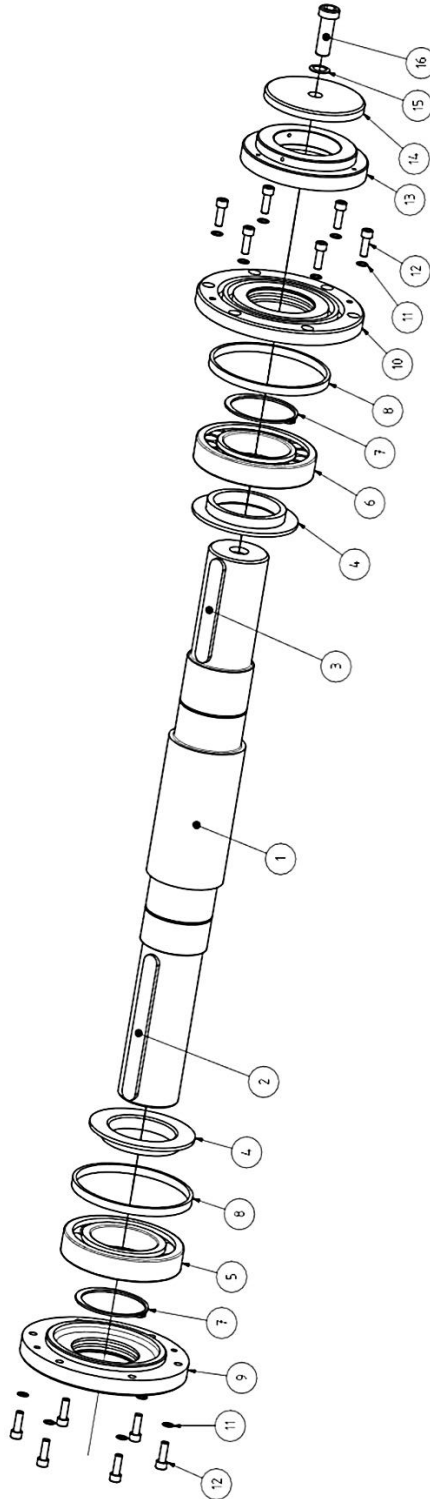

Please refer to the following list for spare and wear parts:

B. Maier & R.Loith GmbH Wood Technology * An der Bleiche 9 * 33813 Oerlinghausen (Germany)

Tel: +49 (0)5202 – 99689 - 0
Fax: +49 (0)5202 – 99689 - 90
Mail: info@ml-wood.com
Web: www.ml-wood.com

Volksbank Paderborn-Höxter-Detmold
BLZ 472 601 21 Konto 3 206 577 300
IBAN-Nr.: DE02 4726 0121 3206 5773 00
SWIFT (BIC) DGPBDE3MXXX

Sparkasse Bielefeld
BLZ 480 501 61 Konto 50 082 999
IBAN-Nr.: DE72 4805 0161 0050 0829 99
SWIFT (BIC) SPBIDE3BXXX

Reg.-Gericht: Lemgo HRB 9088
GF: Dipl.-Ing. Robert Loth
GF: Annika Körtner
Ust-IdNr.: DE 20 63 28 082



ML WOOD

Item.	Pcs.	Description	
1	1	Rotor shaft	S
2	1	Feather key	S
3	1	Feather key	S
4	2	Grease controller	S
5	1	Grooved ball bearing	W
6	1	Pendulum roller bearing (rotor bearing)	W
7	1	Fix ring	S
8	2	Distance ring	S
9	1	Bearing cover	S
10	1	Bearing cover to fixed bearing	S
11	12	Retaining washer, Schnorr	S
12	12	Hexagon socket screw	S
13	1	Cover for standstill controll	S
14	1	Cover	S
15	1	Retaining washer, Schnorr	S
16	1	Hexagon socket screw	S

B. Maier & R.Loith GmbH Wood Technology * An der Bleiche 9 * 33813 Oerlinghausen (Germany)

Tel: +49 (0)5202 – 99689 - 0
Fax: +49 (0)5202 – 99689 - 90
Mail: info@ml-wood.com
Web: www.ml-wood.com

Volksbank Paderborn-Höxter-Detmold
BLZ 472 601 21 Konto 3 206 577 300
IBAN-Nr.: DE02 4726 0121 3206 5773 00
SWIFT (BIC) DGPBDE3MXXX

Sparkasse Bielefeld
BLZ 480 501 61 Konto 50 082 999
IBAN-Nr.: DE72 4805 0161 0050 0829 99
SWIFT (BIC) SPBIDE3BXXX

Reg.-Gericht: Lemgo HRB 9088
GF: Dipl.-Ing. Robert Loth
GF: Annika Körtner
Ust-IdNr.: DE 20 63 28 082



ML WOOD

2.3 Item 13: Rotor fully equipped

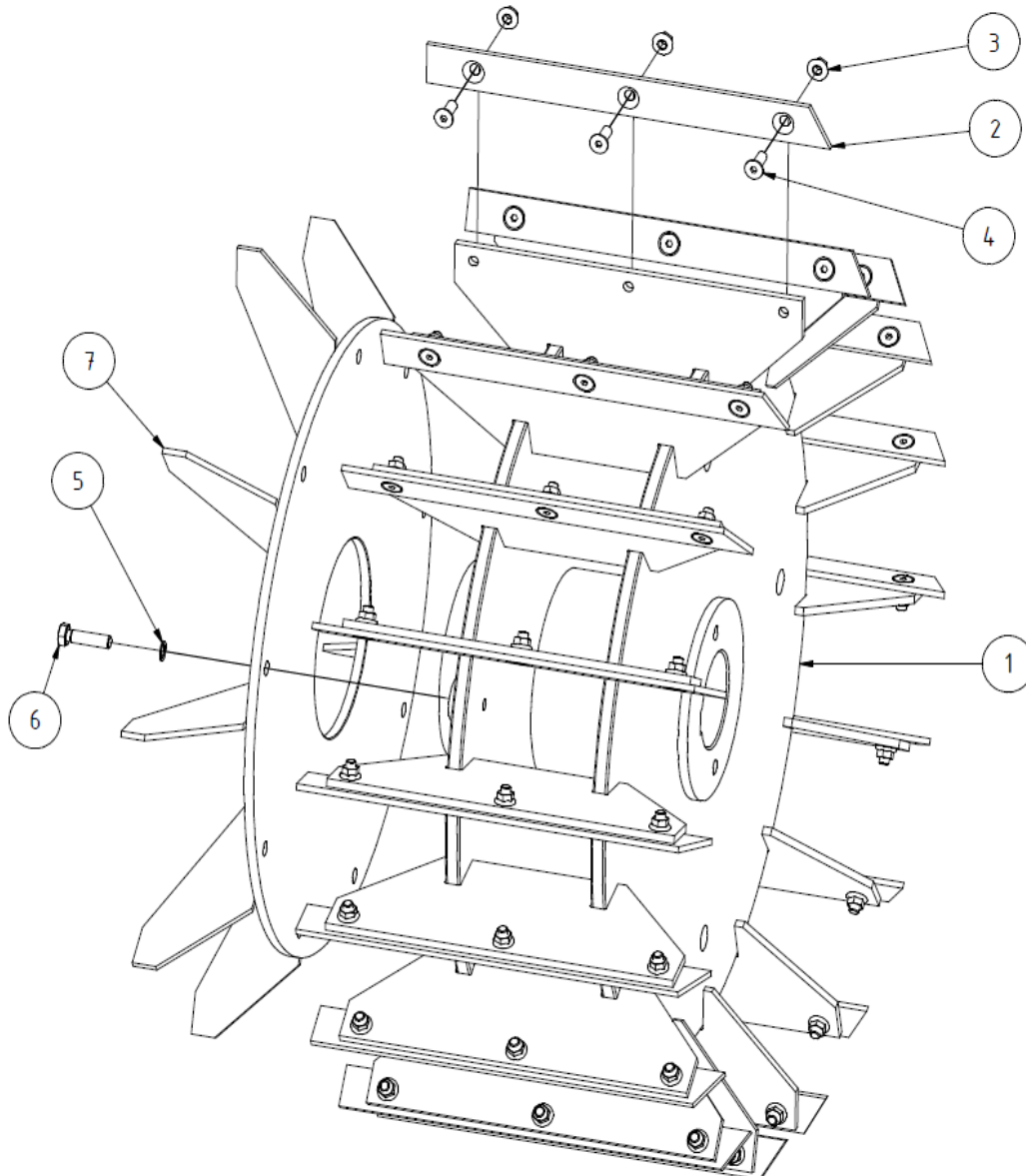

Please refer to the following list for spare and wear parts:

Item 13: Spare and wear parts, Rotor fully equipped

B. Maier & R.Loith GmbH Wood Technology * An der Bleiche 9 * 33813 Oerlinghausen (Germany)

Tel: +49 (0)5202 – 99689 - 0
Fax: +49 (0)5202 – 99689 - 90
Mail: info@ml-wood.com
Web: www.ml-wood.com



Volksbank Paderborn-Höxter-Detmold
BLZ 472 601 21 Konto 3 206 577 300
IBAN-Nr.: DE02 4726 0121 3206 5773 00
SWIFT (BIC) DGPBDE3MXXX

Sparkasse Bielefeld
BLZ 480 501 61 Konto 50 082 999
IBAN-Nr.: DE72 4805 0161 0050 0829 99
SWIFT (BIC) SPBIDE3BXXX

Reg.-Gericht: Lemgo HRB 9088
GF: Dipl.-Ing. Robert Loth
GF: Annika Körtner
Ust-IdNr.: DE 20 63 28 082



ML WOOD

Item.	Pcs.	Description	Item.
Rotor			
13	1	Rotor fully equipped	
1	1	Rotor unequipped	
2	18	Rotor ledger (blades) Hardox 500	W
3	54	Locking nut with flange	S
4	54	Hexagon socket - countersunk screw	S
5	9	Retaining washer, Schnorr	S
6	9	Hexagon socket screw	S
7	1	Ventilator wheel	S

B. Maier & R.Loith GmbH Wood Technology * An der Bleiche 9 * 33813 Oerlinghausen (Germany)

Tel: +49 (0)5202 – 99689 - 0
Fax: +49 (0)5202 – 99689 - 90
Mail: info@ml-wood.com
Web: www.ml-wood.com

Volksbank Paderborn-Höxter-Detmold
BLZ 472 601 21 Konto 3 206 577 300
IBAN-Nr.: DE02 4726 0121 3206 5773 00
SWIFT (BIC) DGPBDE3MXXX

Sparkasse Bielefeld
BLZ 480 501 61 Konto 50 082 999
IBAN-Nr.: DE72 4805 0161 0050 0829 99
SWIFT (BIC) SPBIDE3BXXX

Reg.-Gericht: Lemgo HRB 9088
GF: Dipl.-Ing. Robert Loth
GF: Annika Körtner
Ust-IdNr.: DE 20 63 28 082



ML WOOD

2.4 Item 14: Grind Ring with Screen

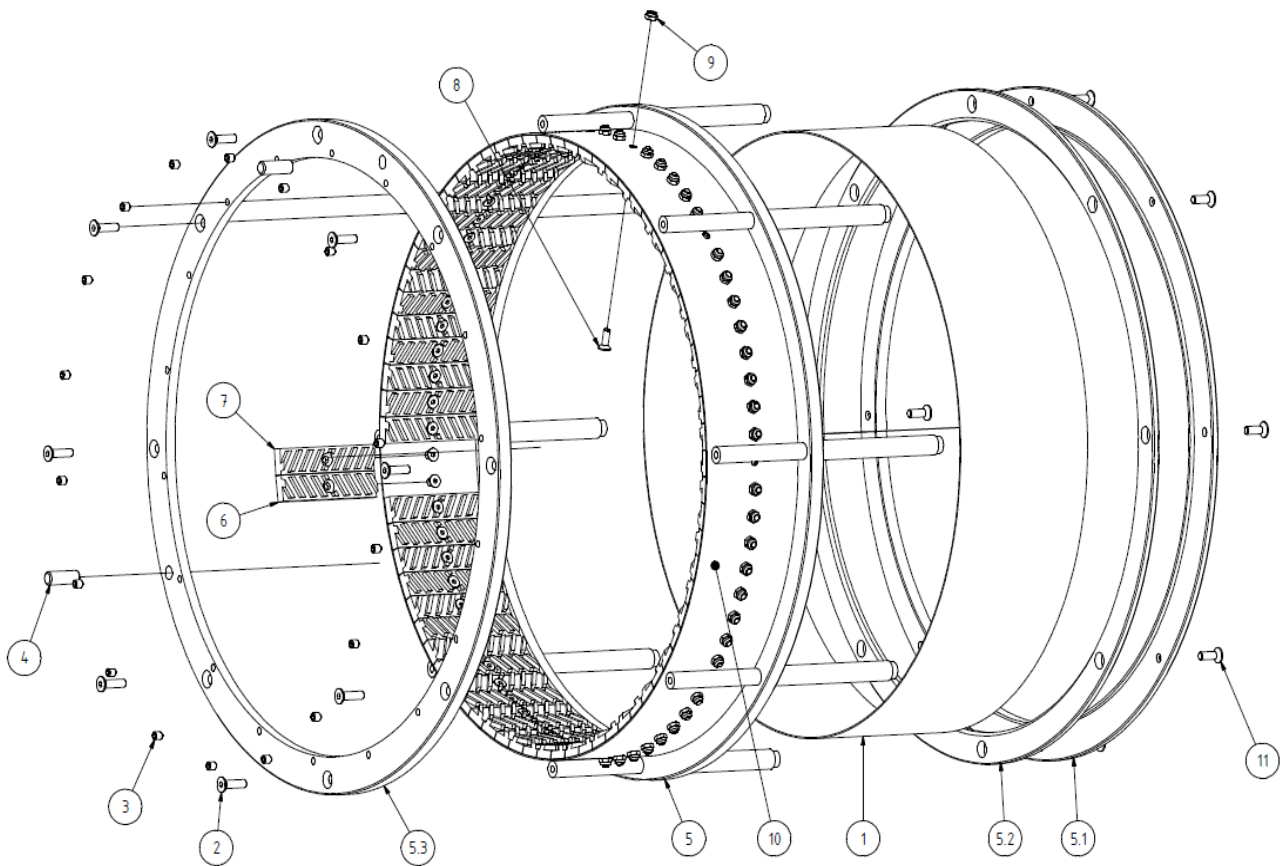

Please refer to the following list for spare and wear parts:

B. Maier & R.Loith GmbH Wood Technology * An der Bleiche 9 * 33813 Oerlinghausen (Germany)

Tel: +49 (0)5202 – 99689 - 0
Fax: +49 (0)5202 – 99689 - 90
Mail: info@ml-wood.com
Web: www.ml-wood.com

Volksbank Paderborn-Höxter-Detmold
BLZ 472 601 21 Konto 3 206 577 300
IBAN-Nr.: DE02 4726 0121 3206 5773 00
SWIFT (BIC) DGPBDE3MXXX

Sparkasse Bielefeld
BLZ 480 501 61 Konto 50 082 999
IBAN-Nr.: DE72 4805 0161 0050 0829 99
SWIFT (BIC) SPBIDE3BXXX

Reg.-Gericht: Lemgo HRB 9088
GF: Dipl.-Ing. Robert Loth
GF: Annika Körtner
Ust-IdNr.: DE 20 63 28 082



ML WOOD

Item 14: Spare and wear parts, Grind Ring with Screen			
Item.	Pcs.	Description	
Grinding Ring			
1	1	Screen	S
2	8	Hexagon socket - countersunk screw	S
3	18	Hexagon fitting screw	S
4	2	Bolt	S
5	1	Frame for grind ring	S
5.1	1	Cover ring	S
5.2	1	Front ring	S
5.3	1	Leading ring	S
6	36	Grind segment 1	W
7	36	Grind segment 2 (mirrored)	W
8	72	Hexagon socket - countersunk screw	S
9	72	Locking nut	S
10	1	Steel jacket perforated	S
11	8	Hexagon socket - countersunk screw	S

B. Maier & R.Loith GmbH Wood Technology * An der Bleiche 9 * 33813 Oerlinghausen (Germany)

Tel: +49 (0)5202 – 99689 - 0
Fax: +49 (0)5202 – 99689 - 90
Mail: info@ml-wood.com
Web: www.ml-wood.com

Volksbank Paderborn-Höxter-Detmold
BLZ 472 601 21 Konto 3 206 577 300
IBAN-Nr.: DE02 4726 0121 3206 5773 00
SWIFT (BIC) DGPBDE3MXXX

Sparkasse Bielefeld
BLZ 480 501 61 Konto 50 082 999
IBAN-Nr.: DE72 4805 0161 0050 0829 99
SWIFT (BIC) SPBIDE3BXXX

Reg.-Gericht: Lemgo HRB 9088
GF: Dipl.-Ing. Robert Loth
GF: Annika Körtner
Ust-IdNr.: DE 20 63 28 082



ML WOOD

2.5 Item 15: V-Belt Drive

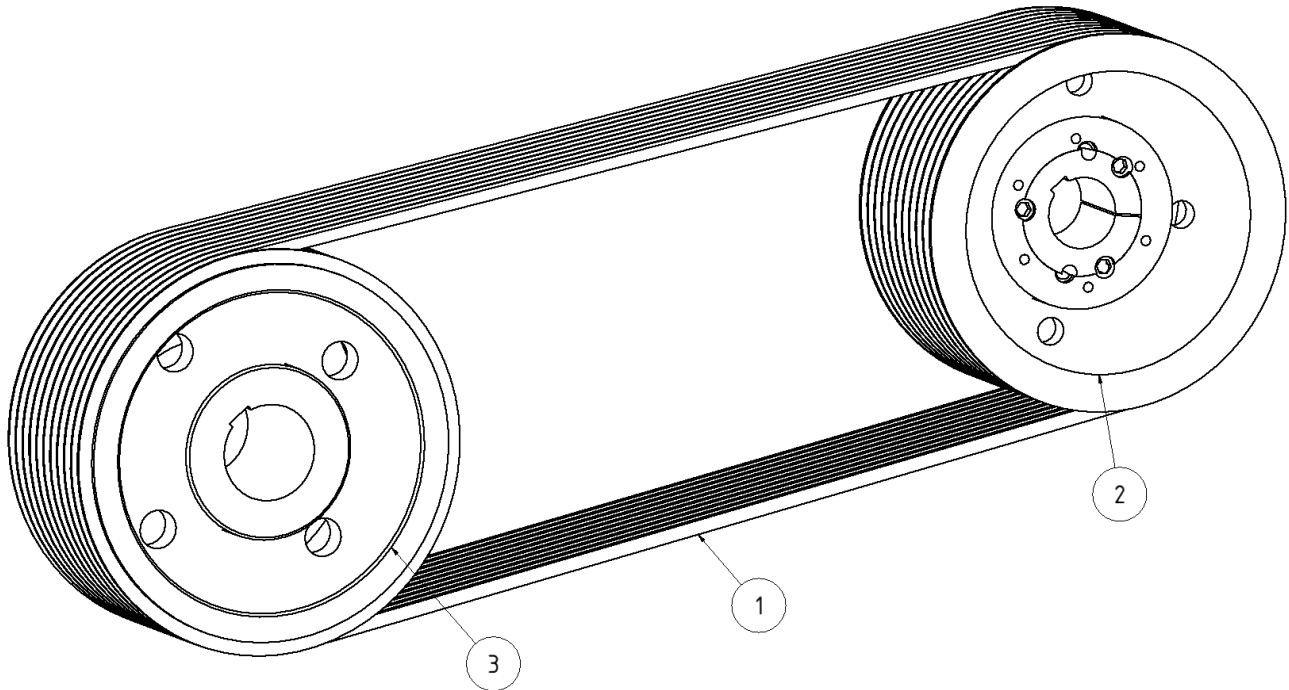

Item 15: Spare and wear parts, V-Belt Drive			
Item.	Pcs.	Description	
1	1	Set of rotor V-belt pulley (not supplied)	 S
2	1	V-belt pulley for rotor with Taperlock-bush	S
3	1	V-belt pulley for motor (not supplied)	S

- End -

B. Maier & R.Loith GmbH Wood Technology * An der Bleiche 9 * 33813 Oerlinghausen (Germany)

Tel: +49 (0)5202 – 99689 - 0
Fax: +49 (0)5202 – 99689 - 90
Mail: info@ml-wood.com
Web: www.ml-wood.com

Volksbank Paderborn-Höxter-Detmold
BLZ 472 601 21 Konto 3 206 577 300
IBAN-Nr.: DE02 4726 0121 3206 5773 00
SWIFT (BIC) DGPBDE3MXXX

Sparkasse Bielefeld
BLZ 480 501 61 Konto 50 082 999
IBAN-Nr.: DE72 4805 0161 0050 0829 99
SWIFT (BIC) SPBIDE3BXXX

Reg.-Gericht: Lemgo HRB 9088
GF: Dipl.-Ing. Robert Loth
GF: Annika Körtner
Ust-IdNr.: DE 20 63 28 082